

LISTA DE RECAMBIOS / DIBUJO

**MAQUINA FLEJADORA PARA FLEJE
DE PLASTICO CON ACUMULADOR
MODELO DYNAMIC 2100**

43.3311.01

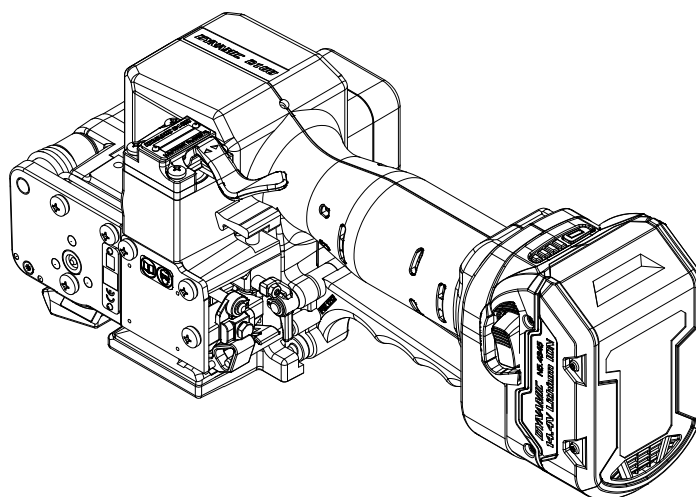

1 Lista de recambios 43.3311.01

43.3311.01	DYNAMIC 2100/16/0.40-0.64		DYNAMIC 2100.01			23.04.2020
Art.n°		en grupo	Pcs.	Descripción	Medidas	Campo
N1.1305			2	TORNILLO	M4 X 7.8	D8
N1.1553		P32.1250	1	TORNILLO DE CABEZA HEXAGONAL	M4 X 8	C12
N1.1904			5	TORNILLO	M5 X 20	C6+
N1.1909			2	TORNILLO CILINDRICO	M3 X 5	D3
N1.1925		P32.0232	4	TORNILLO	M4 X 20	A7+
N1.1929			1	TORNILLO	M5 X 50	D12
N1.1934		P32.0232	6	TORNILLO CILINDRICO	M4 X 50	A19+
N1.1948		P32.0232	1	TORNILLO	M3 X 35	B16
N1.2112		P32.0118	3	TORNILLO AVELLANADO	M4 X 10	B15
N1.2216			1	TORNILLO AVELLANADO	M3 X 8	D4
N1.2223			1	TORNILLO AVELLANADO	M3 X 6	C5
N1.3150		P32.1414	1	VARILLA ROSCADA	M3 X 8	C24
N1.5120		P32.1414	1	TUERCA	M3	C24
N1.6331		P32.0232	4	ANILLO DISTANCIADOR	6 X 12 X 0.5	C22+
N1.6503			6	ARANDELA DE SEGURIDAD	M5	C6+
N1.6504			2	ARANDELA DE SEGURIDAD	M4	D9
N1.6504		P32.0232	10	ARANDELA DE SEGURIDAD	M4	A7+
N1.6504		P32.1250	1	ARANDELA DE SEGURIDAD	M4	C11
N1.6505			2	ARANDELA DE SEGURIDAD	M3	D3
N1.6505		P32.0232	1	ARANDELA DE SEGURIDAD	M3	B16
N1.7206		P32.1139	2	TORNILLO PT	2.2 X 10	D20+
N1.7207		P32.0232	4	TORNILLO PT	3 X 40	A20+
N1.7208		P32.0232	5	TORNILLO PT	3 X 14	A21
N2.1118			1	ANILLO DE SEGURIDAD	6	C24
N2.1121			1	ANILLO DE SEGURIDAD	5	C11
N2.1121		P32.0232	4	ANILLO DE SEGURIDAD	5	D9+
N2.1606			1	ANILLO ELAST.DE RET.	SW6	A21
N2.1610		P32.0232	1	ANILLO ELAST.DE RET.	SB44	B15
N2.1801		P32.0232	1	ANILLO TENSOR	4	C14
N2.2110		P32.1401	1	PASADOR CILINDRICO	4 m6 X 10	B2
N2.2119		P32.0140	1	PASADOR CILINDRICO	4 m6 X 18	C17
N2.2122		P32.0140	2	PASADOR CILINDRICO	3 h6 X 14	C17
N2.2145		P32.0118	3	PASADOR CILINDRICO	4 h6 X 18	C16
N2.2187		P32.0110	2	PASADOR CILINDRICO	3 m6 X 6	C4
N2.2187		P32.1401	1	PASADOR CILINDRICO	3 m6 X 6	A3
N2.2188		P32.1401	3	PASADOR CILINDRICO	5 h6 X 34	B2+
N2.2189		P32.0136	4	PASADOR CILINDRICO	3 m6 X 5	D3
N2.2190		P32.0232	2	PASADOR CILINDRICO	6 h6 X 18	C22
N2.2193			1	PASADOR CILINDRICO	3 m6 X 32	C10
N2.2443		P32.0139	1	PASADOR DE SUJECION	4 X 15	A8
N2.3342		P32.0232	1	RESORTE DE AJUSTE	2 X 2 X 10	C2
N2.4902			4	TORN.CON CAB.DE MART.	1.85 X 4.76	C6+
N2.5157		P32.0232	2	RESORTE DE COMPRESIÓN	0.6 X 4.8 X 20/15.5	C9
N2.5178			2	RESORTE DE COMPRESIÓN	0.32X2.82X20.5/20.5	D10
N2.5235		P32.0232	1	RESORTE DE COMPRESIÓN	0.5 X 4.50 X 42.4/28.5	C18
N2.5237			1	RESORTE DE COMPRESIÓN	0.8 X 4.8 X 25/18.5	C10
N2.5294		P32.0139	1	RESORTE DE COMPRESIÓN	2.5 X 15 X 46.5/9.5	B9
N2.5295		P32.0232	1	RESORTE DE COMPRESIÓN	1.5 X 21 X 27/5.5	B9
N2.5296		P32.0232	1	RESORTE DE COMPRESIÓN	0.5 X 4 X 24/16.5	C9
N2.5822		P32.0232	1	RESORTE A TORSION	1.25 X 12/3.75	D15

[] = Grupo

* = Piezas con desgaste

43.3311.01	DYNAMIC 2100/16/0.40-0.64			DYNAMIC 2100.01		23.04.2020
Art.n°		en grupo	Pcs.	Descripción	Medidas	Campo
N2.5823			1	RESORTE A TORSION	2.8 X 17/4	D4
N3.1134		P32.0232	1	RODAMIENTO DE BOLAS	7 X 22 X7	D21
N3.1134		P32.1021	1	RODAMIENTO DE BOLAS	7 X 22 X7	C22
N3.1157		P32.0118	1	RODAMIENTO DE BOLAS	30 X 42 X 7	C17
N3.1158		P32.0107	1	RODAMIENTO DE BOLAS	8 X 16 X 5	B23
N3.1159		P32.0232	2	RODAMIENTO DE BOLAS	6 X 19 X 6	C22
N3.1160		P32.0119	1	RODAMIENTO DE BOLAS	40 X 52 X 7	A14
N3.1172			2	RODAMIENTO DE BOLAS	30 X 42 X 7	B3+
N3.1178		P32.0120	1	RODAMIENTO DE BOLAS	35 X 44 X 5	A14
N3.1702		P32.0232	6	BOLA	4 MM	D9
N3.2105		P32.0118	3	COJINETE DE AGUJAS	K 4 X 7 X 7 TN	B16
N3.2106			3	COJINETE DE AGUJAS	K 5 X 8 X 10 TN	B3
N3.2346		P32.0110	1	CASQUILLO PARA AGUIAS	8 X 12 X 8	C5
N3.2347		P32.0144	2	CASQUILLO DE AGUJAS	10 X 14 X 12	C21
N3.3172		P32.0136	3	COJIN.DE DESLIZAM.	8 X 10 X 10	C3
N3.3172		P32.1401	1	COJIN.DE DESLIZAM.	8 X 10 X 10	C1
N3.3174		P32.0139	2	COJIN.DE DESLIZAM.	4 X 5.5 X 6	A8+
N3.3174		P32.1141	1	COJIN.DE DESLIZAM.	4 X 5.5 X 6	C21
N3.4509	*	P32.1015	1	AGUJAS A RUEDA LIBRE	6 X 10 X 15	C16
N4.1803		P32.0142	2	PIEZA DE PRESION		B7+
N4.9159			1	ETIQUETA	<<CE>>	C6
N41.9127			1	ETIQUETA	20 X 10 X 0.1	D12
N41.9160		P32.0232	2	ETIQUETA	14.4 VOLT	A21+
N43.9164			1	ETIQUETA	WEEE	B20
N44.9141			1	ETIQUETA	<<DYNAMIC 2100>>	A21
N44.9185			1	ETIQUETA		A7
N44.9192		P32.0232	1	ETIQUETA		--
[N5.1129]	*	P32.0107	1	MOTOR ELECTRICO		B24
[N5.1129]	*	P32.0108	1	MOTOR ELECTRICO		A19
N5.2322		P32.1139	2	MICRO INTERRUPTOR		D20
N5.2702			1	TAPA		B20
N5.2702		P32.0232	1	TAPA		B20
N5.4343		P32.0195	1	PLACA DE CONEXION		A24
N6.6271		P32.0107	1	ANILLO-O	17 X 3.0	B24
N6.6271		P32.0108	1	ANILLO-O	17 X 3.0	A20
P30.1161			1	PERNO DE GUIA		D10
P30.1167			1	PERNO DE GUIA		D10
[P32.0107]		P32.0232	1	MOTOR DE SOLDADURA		B24
[P32.0108]		P32.0232	1	MOTOR DE TENSION		A19
[P32.0110]			1	PLANCHA DEL COJINETE		B6
[P32.0118]		P32.0232	1	ESCALON PLANETARIO		B15
[P32.0119]		P32.0232	1	RUEDA DENTADA		A13
[P32.0120]		P32.0232	1	RUEDA		A14
[P32.0136]			1	CUERPO TENSOR		D2
[P32.0139]		P32.0232	1	GRUPO EYECTOR		A9
[P32.0140]		P32.0232	1	PIEZA DE INSERTATION		C17
[P32.0142]		P32.0232	1	ASIDERO		B7
[P32.0144]		P32.0232	1	BASCULA		D22
[P32.0195]		P32.0232	1	APORTE DE ENERGIA		A23
[P32.0232]			1	MODELO BASE		C1+
P32.1003		P32.1401	1	EJE		C2
P32.1011		P32.0232	2	FIELTRO		C8+

[] = Grupo

* = Piezas con desgaste

43.3311.01	DYNAMIC 2100/16/0.40-0.64		DYNAMIC 2100.01		23.04.2020
Art.n°	en grupo	Pcs.	Descripción	Medidas	Campo
P32.1012	P32.0232	1	PASADOR		C7
P32.1014	P32.0232	1	EJE		C16
[P32.1015]	P32.0232	1	RUEDA CATALINA		C15
P32.1016	P32.1015	1	RUEDA DENTADA		C15
P32.1018	P32.0232	1	VAINA DE RES.DE COMPR.		B18
[P32.1021]	P32.0232	1	EXCENTRICA SOLDADOR		D22
P32.1022	P32.1021	1	EXCENTRICA SOLDADOR		C22
P32.1023	P32.1021	1	PINON		C22
P32.1024	P32.0144	1	BASCULA		C22
P32.1027	P32.0232	1	COJINETE DE BOLAS		D9
P32.1028	P32.0232	1	PERNO		D10
P32.1029	P32.0232	1	PIEZA DE PRESION		C10
P32.1032	P32.0232	1	PERNO DE ARRASTRE		D10
P32.1035	P32.0232	2	ARRASTRADOR		D9+
P32.1037	P32.0232	2	RUEDA DENTADA		C22
P32.1044	P32.0118	1	PORTAPINON		C16
P32.1046	P32.0118	3	RUEDA DE PINON		B15
P32.1047	P32.0118	1	TAPA		B15
P32.1048	P32.0120	1	RUEDA		A14
P32.1049	P32.0119	1	RUEDA DENTADA		A13
P32.1050	P32.0232	1	PALANCA ARTICULADA DELANTE		C2
P32.1051	P32.0232	1	ASIDERO		C16
P32.1052	P32.0232	1	SOPORTE		C15
P32.1053	* P32.0232	1	MORDAZA DE SOLDADURA		D10
P32.1105	P32.1139	1	SOPORTE		D20
P32.1106	P32.1139	2	BOTON GIRATORIO CON RAYA		C20
P32.1107	P32.0195	1	SOPORTE DEL MOTOR		A24
P32.1108	P32.0195	1	BARRA COLECTORA		B22
P32.1119	P32.0107	1	PINON		B23
P32.1120	P32.0107	1	ANILLO DE FIELTRO		B23
P32.1121	P32.0107	2	FUSIBLE DE TORSION		B24
P32.1121	P32.0108	2	FUSIBLE DE TORSION		A20
P32.1122	N5.1129	1	CAJA DE GOMA		A19
P32.1122	N5.1129	1	CAJA DE GOMA		A19
P32.1123	P32.0108	1	PINON		A20
P32.1124	P32.0232	1	PIEZA INTERCALADA		B19
P32.1126	P32.0195	1	CAJA DEL TOMACORRIENTE		B22
P32.1136	P32.0195	1	BARRA COLECTORA		B22
P32.1137	P32.0195	1	BARRA COLECTORA		A22
[P32.1139]	P32.0232	1	ELECTRONICA	14.4V	C21
[P32.1141]	P32.0232	1	CAJA DE MOTOR		A22
P32.1142	P32.0232	1	CAJA DE MOTOR		C23
P32.1143	P32.0232	1	TAPA DE MOTOR		B19
P32.1201		1	PIEZAS INTERCALADA DE ACERO		D7
P32.1203	*	1	BALIZA DE SOLDADURA		D7
P32.1204	*	1	CHUCHILLA		C10
P32.1206		1	CAJA DE GUIA		C11
P32.1208		1	CASQUILLO DE CENTRAJE		C11
P32.1210		2	CASQUILLO DE CENTRAJE		C11+
P32.1211		1	TAPA		C12
P32.1212		1	ASIDERO		C23
P32.1216		1	RODILLO DE PRESION		C2

[] = Grupo

* = Piezas con desgaste

43.3311.01	DYNAMIC 2100/16/0.40-0.64		DYNAMIC 2100.01		23.04.2020	
Art.n°		en grupo	Pcs.	Descripción	Medidas	Campo
P32.1217			3	RUEDA DE PINON		B4
P32.1218			3	VAINA		B4
P32.1219	*		1	ROLLO DE TENSOR		B4
P32.1222	*		1	MORDAZA DE SUJECCION		C3
P32.1223	*		1	MORDAZA DE SUJECCION		C3
P32.1224	*		1	MORDAZA DE SUJECCION		C3
P32.1228			1	SOPORTE DE LA MORDAZA		C3
P32.1229			1	SOPORTE DE LA MORDAZA		B3
P32.1237			1	TOPE DE CINTA		D4
P32.1238		P32.0110	1	PLANCHA DEL COJINETE		C5
P32.1246			1	GUIA CINTA		C4
P32.1248			1	ASIDERO BASCULANTE		C11
P32.1249			1	ASIDERO BASCULANTE		C10
[P32.1250]			1	PASADOR		C12
P32.1251		P32.1250	1	PASADOR		C11
P32.1252		P32.1250	1	PIEZA DE PRESION		C11
P32.1254		P32.0136	1	CUERPO TENSOR		C4
[P32.1401]		P32.0232	1	CAJA		A2
P32.1402		P32.1401	1	CAJA		A1+
P32.1403		P32.0139	1	HUSILLO		B9
P32.1404		P32.0139	1	CORREDERA DEL RESORTE		A9
P32.1405		P32.0139	1	ROLLO		A9
P32.1406		P32.0142	1	ASIDERO		B7
P32.1407		P32.0232	1	TAPA		B7
P32.1408		P32.0232	1	GANCHO DE CIERRE		B17
P32.1409		P32.0232	1	BRAZO		B16
P32.1410		P32.0232	1	PASADOR		C10
P32.1411		P32.0232	1	ASIDERO		C18
P32.1412		P32.0140	1	PIEZA DE INSERTATION		C17
[P32.1414]			1	ASIDERO		C24
P32.1415			1	EYE DE ASIDERO		C24
P32.1416		P32.0232	1	PLACA FIJA		A9
P32.1417		P32.0232	1	BASCULA DE CAMBIO		B17
P32.1422		P32.1414	1	ASIDERO		C24

[] = Grupo

* = Piezas con desgaste

2 Dibujo 43.3311.01

